



Switchable magnet systems for stacking pieces of sheet metal

These magnet systems, comprising permanent magnets and a coil, are used in particular for transporting suspended ferromagnetic items of sheet metal. These systems can be used especially cost-effectively wherever there is at least a 50% condition of „magnetically adhering“. This ensures that the switch-on period of the coil is not greater than 50%. This condition is always met for applications involving stacking systems. These systems are optimized in respect of high levels of adhesive power, a mean deep action and a low compensation current. These components effect an electrical time constant on the part of the systems of approx. 50 ms to 120 ms. It is markedly less than in the case of pure electromagnets. Given today's usual stacking speed, it is necessary to provide the magnet systems with control electronics which allow a switching frequency of up to 200 switches per minute and more. Such a high switching frequency can, however, only be realized if the falling sheet metal is subjected to an additional force so that the depositing process is accelerated such as is the case with destacking systems.

1. The displacement system (monostable)

This system group is today used principally in stacking systems because it allows a high switching frequency at the same time as a low compensation current; this suits the increasing stacking speed.

Functional principle

The principle of the design of these magnet systems is presented in Fig. 1. Two types are distinguished. The Type 1 system shows the permanent magnet, the coil and the flux conductance parts. The permanent magnet drives a magnetic flux through the iron items, with the result that the ends of the field lines are able to leave the north pole which is generated and enter the south poles. The pattern of the field lines is, in rough approximation, similar to that of a semicircle. It is also approximately the case that the radius of the semicircle is a dimension for the deep action of the system. Deep action should be understood in this context to refer to the distance at which a 0.5 mm thick item of sheet metal just jumps with the whole area of the magnet system being taken up. The permanent magnet is restricted on one side by a U-section, on the other, an iron plate forms the close. This iron plate has a double function. Firstly, it collects the magnetic flux of the permanent magnet and conducts it via the centre bridge to the north pole of the system; secondly, the iron plate forms the bypass for the flux compensation in the event of the current flowing through the coil; the bypass is described in greater detail below. If there is no current flowing through the coil, the adhesive power of the magnet system is generated solely by the permanent magnet. In the case of the coil, it is now possible to make current flow either in the supporting direction or in the compensating direction. The supporting direction refers to the permanent magnet being supported by the coil current and the adhesive power thus being still further increased. If the current flows in the compensating direction (usual case), the adhesive power of the permanent magnet is weakened. This weakening can be taken so far that almost none of the field lines leaves the magnet system, resulting in the adhesive power disappearing. In this case, the iron plate on the magnet has the function of conducting the magnetic flux of the coil in such a way that the magnetic flux of the permanent magnet is exactly compensated. This logic implies that the magnet system is magnetically neutral when a current is flowing, or, viewed the other way, that the max. adhesive power occurs when no current is flowing. This corresponds to the normal type of operation in sheet metal stacking. The exact opposite is the case as regards electromagnets.

Fig. 1: Schematic diagram of displacement systems

Type 1: Displacement system with a permanent magnet

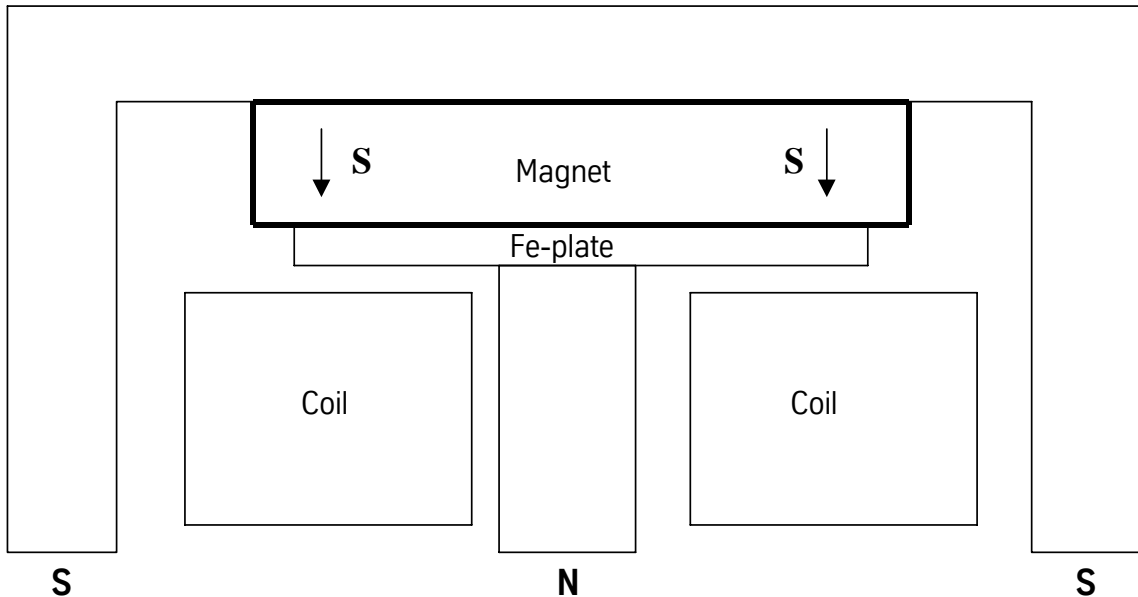

Type 2A: Displacement system with two permanent magnets

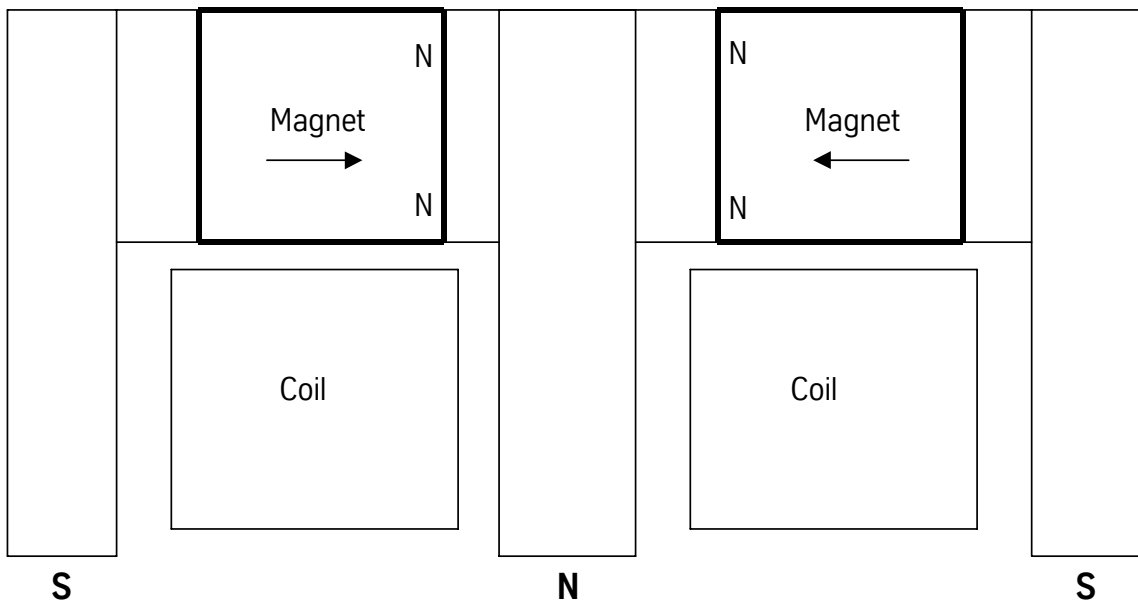

The system of Type 2A is equipped with 2 magnets which have their poles facing each other. These permanent magnets lead the magnetic flux through the centre bridge of the adhesion area so that the indicated polarity is generated at the adhesion area. The advantages of this version can be seen in the higher adhesive power (2 magnets), although the greater system height may cause difficulties. In particular, this is a system which is „open“ at the top, i.e. the fieldlines leave the system „upward“ to the same extent also; it should therefore be ensured that no ferromagnetic material may be used directly above the hanging installation of the system, since this would have the effect of a magnetic „short circuit“. This would greatly reduce the adhesive power. Type 1 systems are enclosed, have a low construction height and can be more easily compensated as a result of the bypass.

This configuration is recommended when RES magnets have to be used as a result of a high adhesive power requirement, because these magnets are markedly more difficult to compensate in the **Type 2A** configuration, since there is no bypass. As a result, the magnet itself must be weakened by the coil current. Owing to the high coil current, the heating is greater, leading to the possible switch-on period being shorter. The preferred use for displacement systems of **Type 2A** can thus be seen in the case of slower systems which have lower switching frequencies, such as in the case of sheet loaders and load-elevating systems.

These restrictions mean that one version has established itself which has an enclosed construction and which may be regarded as a compromise between **Type 1** and **Type 2A**. This version is presented as **Type 2B** in the following sketch.

Type 2B: Enclosed displacement system with two permanent magnets

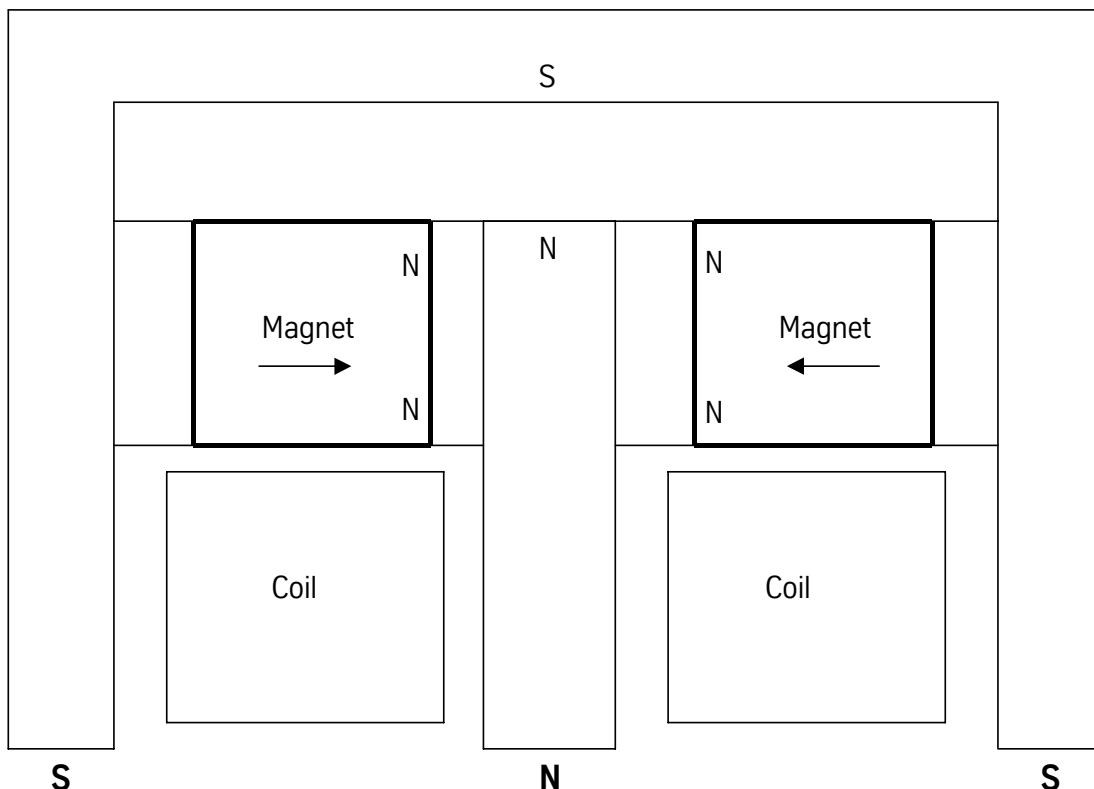

The iron casing at the back of the system makes it possible to obtain the magnetically enclosed configuration. However, the distance between the north pole, which is open at the back, and the large iron area (south pole) is very critical. If too small a distance is chosen, a great amount of adhesive power is lost. On the other hand, this „bypass“ helps in terms of compensation. This distance thus allows the compromise of high adhesive power and low compensation current to be optimized.

The systems of **Type 1** and **Type 2A** may of course be interconnected, resulting in multipole versions.

2. Bistable switchable magnet systems

Viewed historically, this system type was the first electrically switchable permanent magnet system and is today of hardly any importance any longer because of its high pulse power when switching from the „magnetic“ state to the „neutral“ state. Nevertheless, it may be practical to use it wherever a low switching frequency is guaranteed and the „magnetically neutral“ state must be on over longer periods. The switching time of this type of magnet is usually markedly higher than that of the monostable systems. There are 2 types of switchover systems here also, **Type 1** representing a „rapid-switching“ version and **Type 2a** version which is specially suitable for load-elevating applications.

2.1 The functional principle

It is designed with 2 poles and has two kinds of magnets; this makes the system very interesting from the point of view of the technology of magnets. It is designed as presented in **Fig. 2**.

Fig. 2: Bistable magnetic system of Type 1 with two magnetic materials

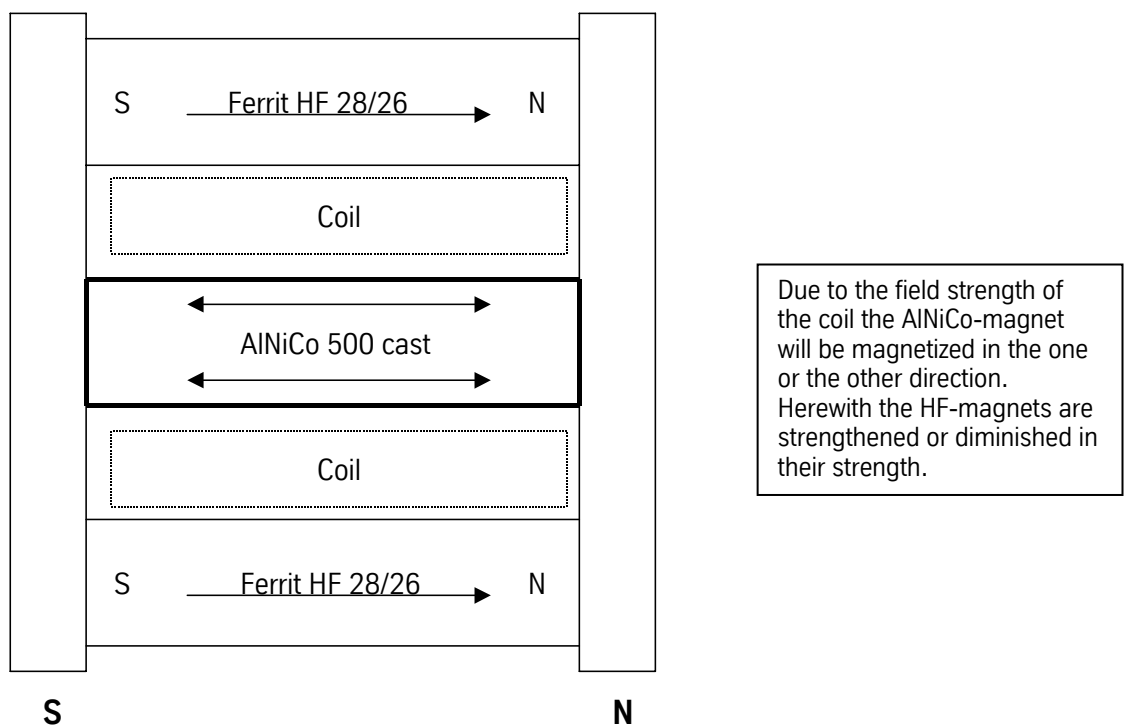

The advantage of this system is that both switching states („magnetic“ and „neutral“) are stable and that electrical energy is required only for switching over the states. However, a high level of switching current is necessary, putting a heavy load on the mains supply; this involves a development of heat which then allows a switching frequency of only approx. 60 switches per minute.

This system also is open at the top, making it impermissible for ferromagnetic material to be located directly over the magnet system (similarly to that of the displacement system of **Type 2A**).

There is an additional problem in minimizing the residual adhesive power, because the AlNiCo magnet must compensate exactly the magnetic field of the two ferrite magnets, i.e. it must

have the same magnetic flux. Since the magnetic values, however, are subject to scatter, there is always a certain residual adhesive power remaining. This system is interesting because the very different demagnetization curves of the two magnet types have been ideally combined. The high remanence of the AlNiCo 500 cast is necessary so as to make available the necessary flux in as small a space as possible in the highly enclosed system; the coil diameter may thus be kept small, since the full hysteresis curve of the magnet traverses the coil field. In addition, it is also important that the AlNiCo magnet has a low coercivity so as to facilitate remagnetizing by means of the coil.

On the other hand, the high coercivity of the ferrite magnet is used, because this magnet must not be affected by the coil field. Everywhere that it is unavoidable to maintain both magnetic states over longer periods, there is no alternative to these systems, unless electric systems are used, which, however, involve a safety risk in the „magnetic“ state if the electricity fails.

The switchover system of **Type 2** represents an enclosed version which has a particularly high specific density of force. Viewed from the perspective of its magnetic circuit, this system is the displacement system of **Type 2B** skillfully combined with AlNiCo magnets which make it possible to neutralize the magnetic flux. In principle, this is a 4-pole configuration, only 2 main poles of which are brought out as presented in **Fig. 3**. The AlNiCo magnets operate, on the one hand, as counter magnets, i.e. for reducing the leakage flux, on the other, when they are re-poled, for compensating the magnetic flux of the ferrites.

Fig. 3: Closed bistable magnet system of Type 2 with 2 magnetic materials

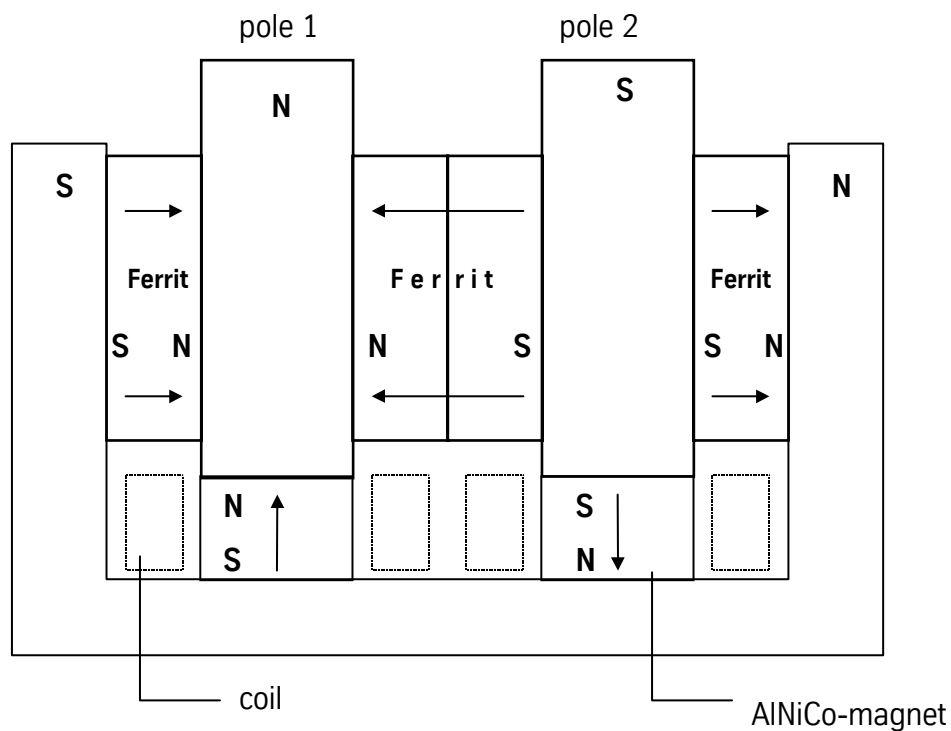

This 2-pole version may easily be expanded by extending the outer poles into a 4-pole system. A configuration of this kind, itself weighing 7.5 tonnes, achieved an adhesive power of approx. 60 tonnes with direct contact. These systems are for the automatic transportation of coils in the case of coil weights of up to 25 tonnes.



3.3 Adhesive power curves

The pertinent adhesive power curves are characteristic for each magnet system. The principle of the adhesive power curve is presented in **Fig. 4**. It is striking that the adhesive power does not have a linear pattern as a function of distance, but, as the distance increases, it decreases disproportionately greatly in particular in the case of smaller air gaps. It is precisely this behaviour which makes the design of magnet systems so complicated. In addition, the adhesive power is a function of the thickness of the sheet metal. As the thickness of the sheet metal increases, the adhesive power rises. This is a thoroughly positive effect, which is very useful in design, because as the thickness of the sheet metal increases, the weight of the sheet metal also increases, with the result that the adhesive power also rises. The safety factor when transporting sheets thus remains largely constant over a wide range of thicknesses of sheet metal. The adhesive power curves are generally to be understood as mean value curves, so that deviations may also arise as a result of production.

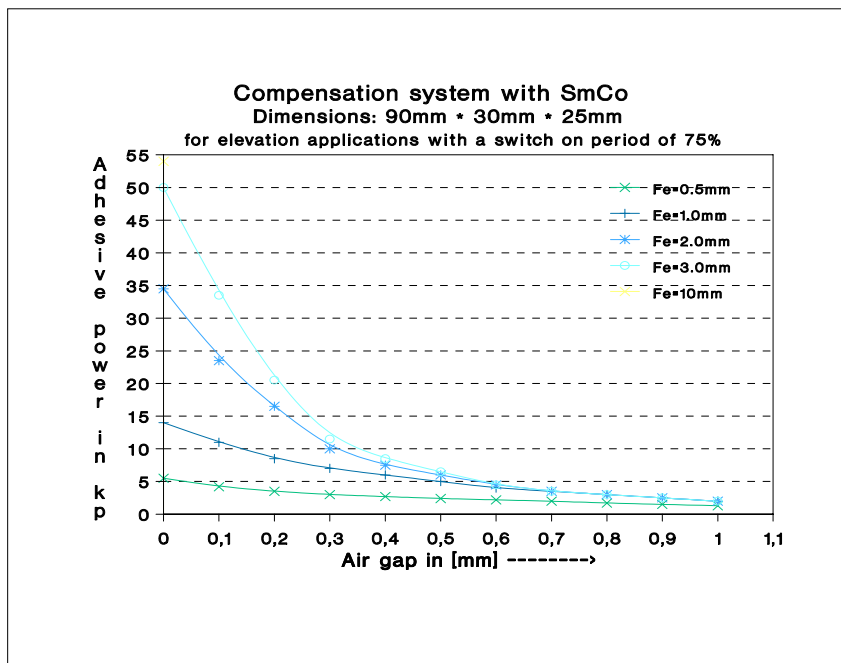

Fig. 4: Adhesive power curve of a magnet system with different thickness of sheet metal

3.4 Deep action

The concept of deep action has already been mentioned, and it will be explained in somewhat more detail at this point. If the distance between the north pole and the south pole is designated the pole pitch or pole distance, it may be said that the deep action also becomes greater as the pole distance increases. Expressed in different terms, this means that the wider the magnet system is, the greater is the deep action. On the other hand, the adhesive power also increases with the system width. Stacking processes usually involve a high level of adhesive power being desired for secure transportation of the metal sheets, but only a small deep action is desired in comparison with this, since the sheet metal which has just been deposited should not immediately be attracted again. A high adhesive power up to a distance of 10 mm (wear-resistant sheet metal and transportation belt traverse a range of 4 mm...6 mm) would be ideal, and immediately afterward an adhesive power which decreases again very significantly, so that the falling sheet metal is not again attracted. This contradictory demand can be met only approximately and must be adapted to the specific requirements.

4. Suction systems

Another type of electrically switching magnet system which has permanent magnets is based on a large deep action. These systems are for automatic destacking sheets, as already mentioned. So as to cause sheet metal items to jump from a relatively large distance, a large pole pitch is necessary.

4.1 The functional principle

These systems are, as presented in **Fig. 5**, equipped with a coil, which primarily has the task of causing the sheet to jump. So as to keep the switch-on period as short as possible, the adhesive power of the permanent magnet, after the sheet metal has jumped, should be provided in such a way that the coil can then be switched off again. The sheet metal is then further transported by means of a belt below the system. The coil thus has only a switch-on period of approx. 10%, enabling a large current increase to be achieved.

Fig. 5: Schematic presentation of suction systems

Type 1: Suction system with two SmCo magnets

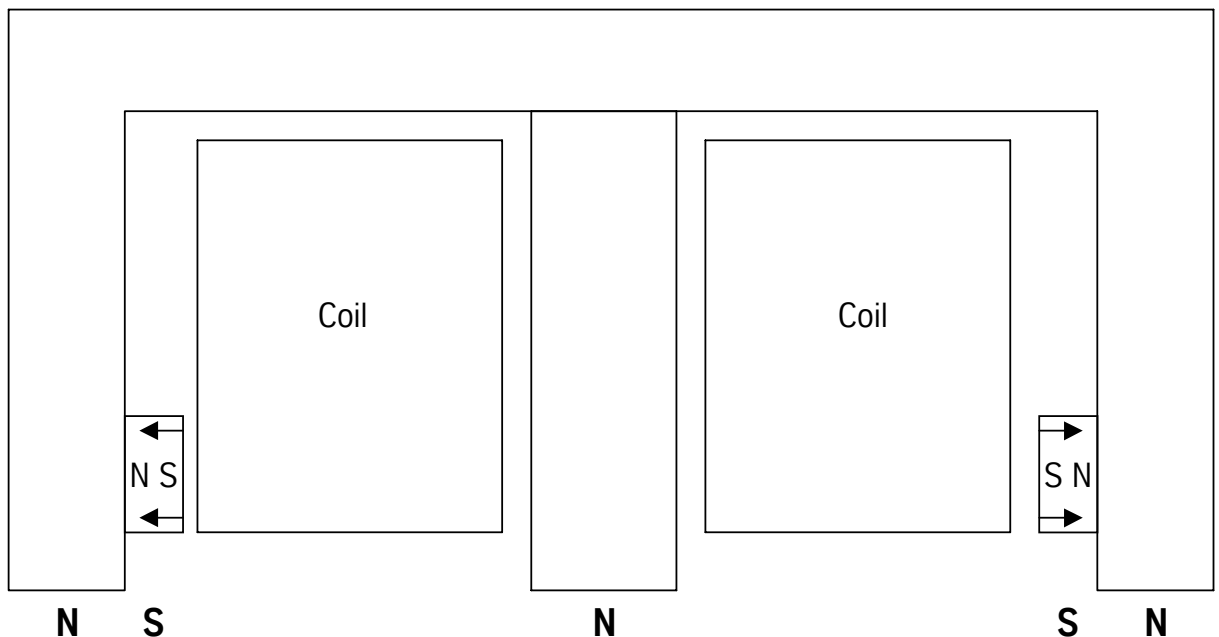

Type 2: Suction system with four SmCo magnets

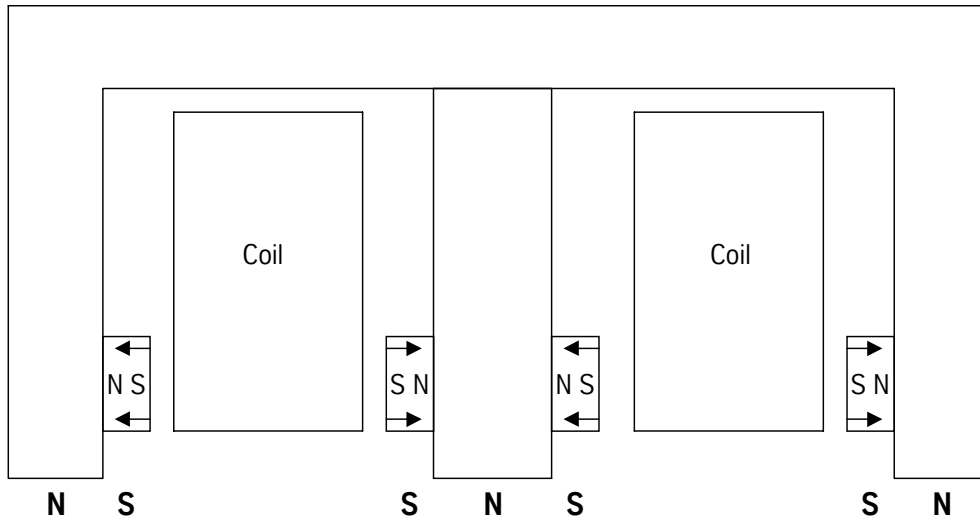

Displacement systems, as already described, are not suitable for this purpose, since the range (pole pitch) of the permanent magnet part is just as large as that of the electromagnet part. **Type 2** represents the best compromise between permanent magnetic and electromagnetic pole pitch, as is presented once again in **Fig. 6**:

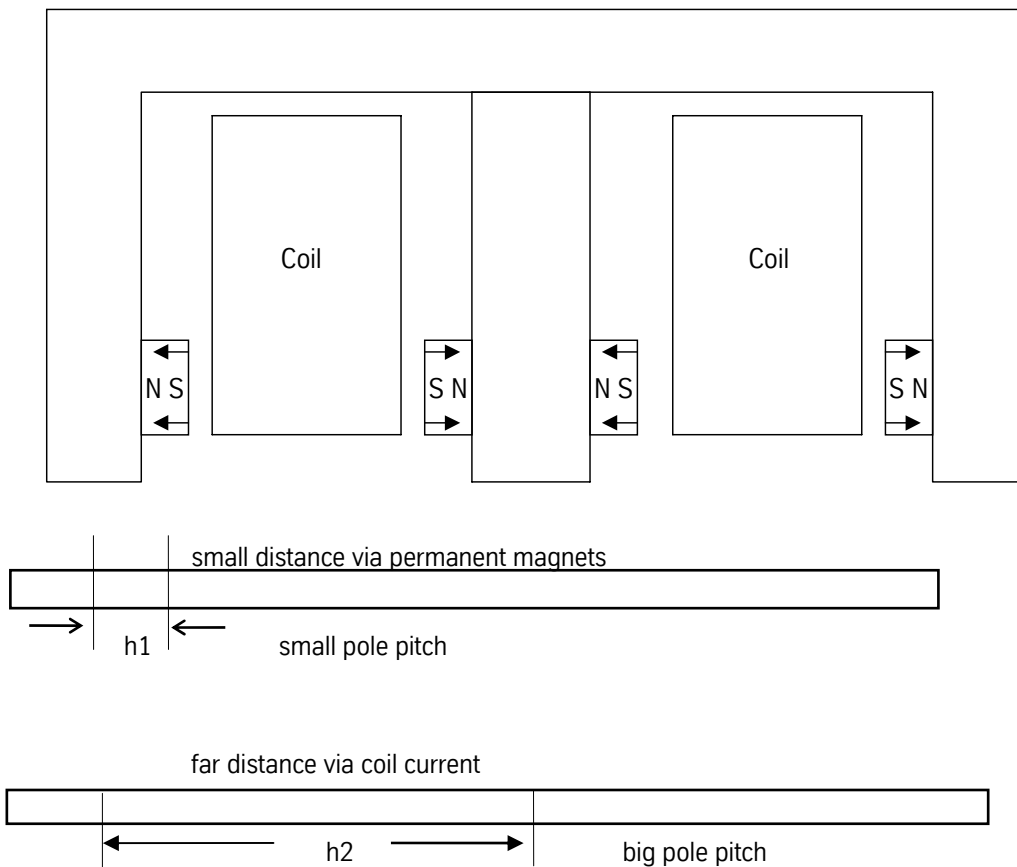

Fig. 6: Representation of the two pole pitches in one system