



Permanent magnetic couplings and brakes for drive applications



Index

Classification and principle of design	2
Synchronous couplings:	3
Disc couplings	5
Concentric ring coupling	6
Hysteresis clutches and brakes	8
Eddy current clutches and brakes	9
Technical advice and supply of samples	11
Mass Production	11
General note (liability)	11



Classification and principle of design

Permanent magnetic couplings and brakes can be divided into three basic types:

- Synchronous couplings, which include the disc and concentric ring couplings
- Hysteresis clutches and brakes
- Eddy current clutches and brakes

For all types of coupling and brake the relevant efficiency equation¹⁾ is

$$P_1 - P_v - P_2 = 0.$$

P_1 is the influx power from the drive side.

P_2 is the transmitted power from the driven side and

P_v is the power loss which occurs through the transmission mechanism in coupling and brake.

In synchronous couplings $P_v = 0$, as the slip $S = 0$. (See instruction for application and assembly on page 7). On the drive and driven sides, permanent magnets are set opposite one another with an equal, even number of poles mirror balanced (disc couplings: fig. 1) or dynamically balanced (concentric ring couplings: fig. 2). The magnetic requirements for synchronous couplings

- permeability $\mu_{rev} \rightarrow 1$
- coercive field strength as great as possible

are best met by the ceramic materials barium or strontium ferrite as well as intermetallic combinations of rare earths and cobalt.

One of the halves of the synchronous coupling – suitable for the hysteresis clutches by a ring or disc made from a permanently magnetic material with relatively greater remanence and permeability and relatively smaller coercive field strength, so that this half of the coupling can be magnetically reversed from the other for greater resistance (fig. 3).

Finally, in eddy current clutches and brakes $P_v > 0$, as $S > 0$. One of the halves of the synchronous coupling – suitable for the drive side – is replaced here by an electrical conductor, iron backed, in ring or disc form (fig. 4).

- General advantages of permanent magnetic couplings and brakes: free of wear, no contact, maintenance-free, low bearing-friction on concentric ring couplings, unlimited life under normal conditions of use.

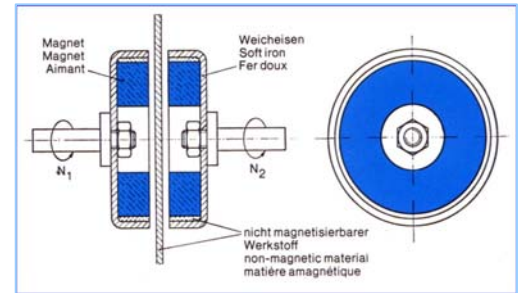

Fig.1 Design of a disc coupling

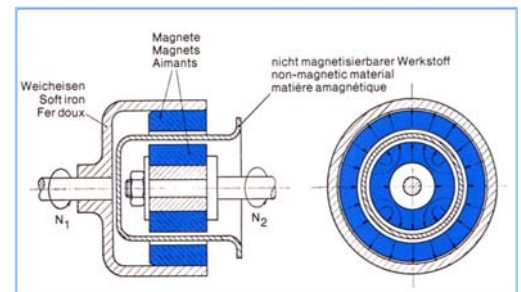

Fig.2 Design of a concentric ring coupling

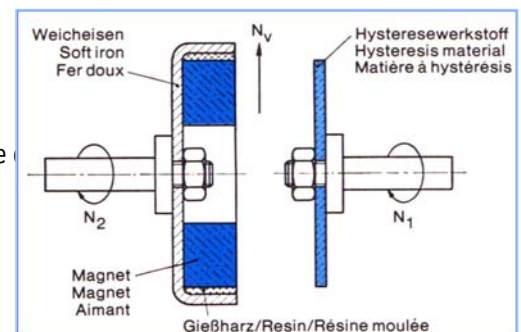

Fig.3 Design of a hysteresis clutch or brake

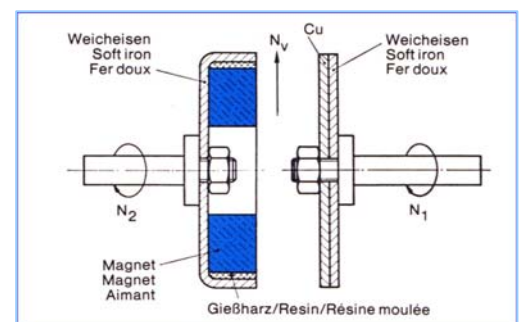

Fig.4 Design of an eddy current coupling or brake

¹⁾ Gernhardt, P.: „Dauermagnetische Kupplungen (Einteilung, Wirkungsweise und Dimensionierung)“ TEW-Technical report 2 (1962), pages 153-159.

Synchronous couplings disc and concentric couplings

Design and types

The disc and concentric ring couplings developed by us are manufactured and offered – according to application, capacity and required performance – in the following materials:

- Ceramic materials, hard ferrite (HF): HF 8/22, HF 24/20
- Metallic materials, AlNiCo: AlNiCo 18/10, AlNiCo 36/14, AlNiCo 40/5
- Rare Earth materials: SmCo, NdFeB

In practice these elements have proved themselves in numerous applications. With relatively small magnet sizes they allow the transmission of great torques in closed spaces through partitions without the use of gaskets, seals and glands. Of particular advantage is the fact, that through correct structural design utilising air gaps, all couplings work free of friction and thus free of wear. Tables 1 – 2b contain our disc and concentric ring couplings in 5 types. The basic design of these couplings can be seen in figs. 1 and 2. For examples of design see figs. 5 and 6. Sizes of the magnets and iron mountings necessary to achieve the given torque can be found in the tables on pages 5 – 6.

When choosing a coupling type please note that at the start of torque movement, and in some cases through shock loading, higher torque can occur than could for instance be calculated from nominal power and number of revs. of a motor. If the coupling is not just to run purely as an overload coupling, then possible additional starting torque must also be considered. The drive gear should be run up slowly or the size of coupling chosen so high that the coupling moment is always above the maximum driving moment. If the coupling should break away no magnetic changes will occur. However, for synchronisation it is necessary to bring both coupling parts to a standstill and run up again. The standard couplings shown in tables 1, 2a and b, 3 and 4 are in mass production.

Instructions for application and assembly

Disc couplings

The application possibilities are similar to those subsequently described for concentric ring couplings; the partition walls can be plain and flat. It should be noted, that the relatively high axial power must be absorbed by a suitable bearing. Are single ring magnets delivered by us for self-construction by the customer the following has to be noticed: The distance between the rings in our packaging is not allowed to be reduced in order to maintain the magnetic values. Furthermore the magnets should not be twisted against each other before they are fitted into the housing. In the case of delivering single rings the magnetisation of the completed coupling is recommended. After the fitting into the iron mounting a decrease of the torque value mentioned in tables 1 to 2b can only be expected at a small rate of 5 to 10%. Even if the magnets have direct contact or are twisted against each other. Our instructions are general suggestions relating to the materials. They do not discharge the user from noticing other constructive aspects which might occur specially in each individual case when couplings are made ready for use. We are gladly prepared to provide assistance with the construction.

Concentric ring couplings

Transmission of turning movement from wet to dry media in liquid and gas meters. Because of high rigidity small angle movements from closed spaces can be transmitted to indicating instruments.

Application: maintenance-free pumps, vacuums, compressor construction and many more.

- Most designs need an interface between inner and outer compartments made from a tubular or cupshaped, non-magnetic material. See fig.2. In order to avoid eddy currents this should be electrically non-conductive e.g. made of plastic. For high pressures one could use austenitic chrome-nickel steels with high electrical resistance e.g. REMANIT 1.4301. Where the number of revolutions (rpm) is higher, care must be taken to allow sufficient cooling of the metallic partition wall. To level out the resulting power loss, a correspondingly higher required power should be chosen.

- If concentric ring couplings in HF 8/22 are used without soft iron mountings the given torque and rigidity are reduced by approx. 10%. HF-materials are extensively resistant to chemicals. In special cases metal protection by using non-magnetic chrome-nickel steels and plastic is possible. Linear torque increase is possible through a stringing together of individual rings or systems, but then the whole unit must be completely magnetised.

Temperature behaviour of the magnets

The working range of HF-couplings is between -30°C and $+150^{\circ}\text{C}$. If the working temperature is raised or lowered, the transmitted torque decreases or increases linearly by approx. $4 \cdot 10^{-3} \text{K}^{-1} = 4\%/10^{\circ}\text{C}$. For SmCo -190°C to $+250^{\circ}\text{C}$; in this range torques increase or decrease by $0.8\%/10^{\circ}\text{C}$. The respective coupling reaches its initial value again at room temperature as the temperature effect is reversible. For temperatures above 250°C we develop special couplings in AlNiCo on request. This type of AlNiCo coupling can be used at temperatures up to 400°C maintained over long periods.

Example of design for a disc coupling

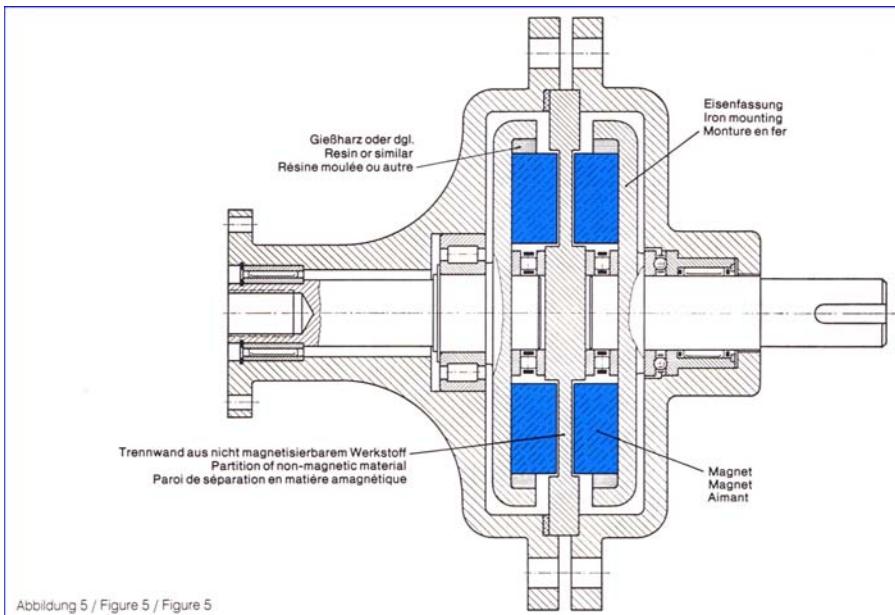

Example of design for a concentric ring coupling

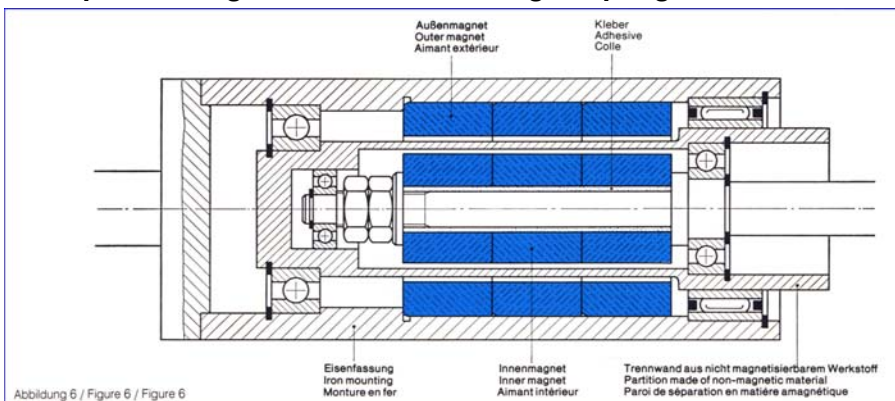

Disc couplings

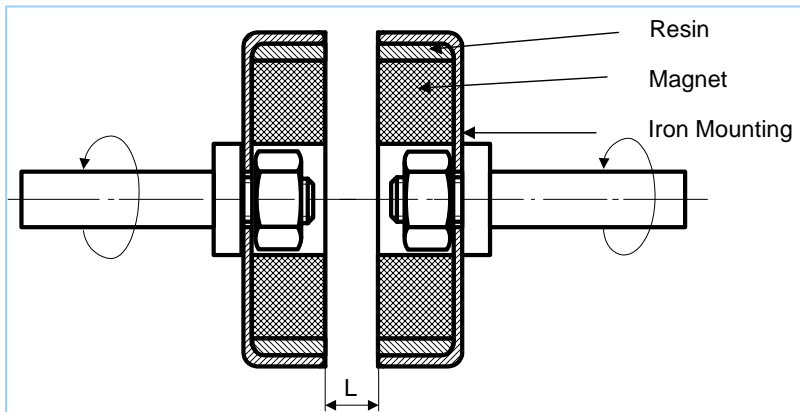

Please find below an extract of our product range. Any other types are available on demand.

Disc couplings in HF 24/20 and SmCo

Torque in Ncm*) with air gap LL in mm				Axial force in N with air gap LL in mm				Magnet sizes			Sizes magnet with iron mounting		Bore in the iron mounting	Type
1	3	5	10	1	3	5	10	Outer Ø mm	Inner Ø mm	Hight mm	Outer Ø mm	Height mm	Ø mm	
10	7	5	2	13	8	5	2	41 ± 0,6	24 ± 0,6	8	50 ± 0,2	9,5 ± 0,15	-	175 055
35	23	17	7	50	30	18	5	53 ± 0,7	23 ± 0,5	8	63 ± 0,2	10 ± 0,15	-	175 056
80	60	44	24	64	39	26	10	68 ± 1,5	32 ± 0,7	10	80 ± 0,25	13 ± 0,2	-	175 057
175	125	100	45	172	113	80	25	84 ± 4,0	32 ± 1,0	12	100 ± 0,25	16 ± 0,2	-	175 058
500	360	260	120	340	210	135	55	85 ± 1,0	32	10	100 ± 0,25	13 ± 0,2	32	175 059²⁾
285	240	190	105	210	142	110	54	100 ± 2,0	50 ± 1,0	15	125 ± 0,25	20 ± 0,2	-	175 060
780	635	480	260	330	216	180	95	124 ± 3,0	56 ± 3,0	18	150 ± 0,3	24 ± 0,2	-	175 061
950	800	600	380	440	310	257	135	140 ± 2,0	70 ± 1,0	21	165 ± 0,3	27 ± 0,2	-	175 062
2800	2200	1600	800	1020	657	427	196	140	60	10	150 ± 0,3	16 ± 0,2	25 ± 0,05	175 063²⁾
1670	1400	1050	660	778	545	453	242	180	80	20	195	28 ± 0,2	32 ± 0,05	175 064²⁾
2500	2100	1600	1000	1182	827	688	367	214 ± 2,0	68 ± 1,0	21	235	27 ± 0,3	-	175 065²⁾

Table 1

*) 1 Ncm = 100 cmp = 0.00738 ft lbs

1) Special type in Hartferrit

2) Special type in SmCo

Special type cannot be delivered from stock.

Concentric ring couplings in HF 8/22

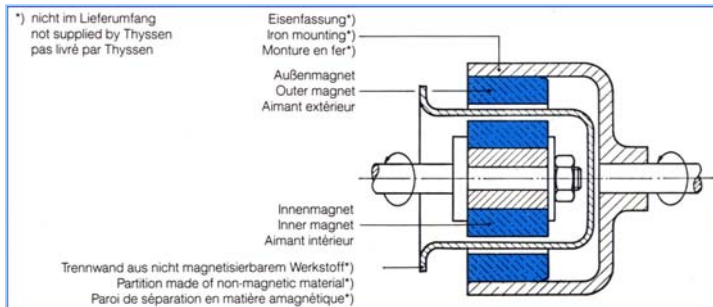

Please find below an extract of our product range. Any other types are available on demand.

Concentric ring couplings in HF 8/22 with air gap ≤ 3 mm

Table 2a

Torque Ncm*)	Inner magnet			Outer magnet			Air gap LL	Wall thickness of iron mountings mm	Type
	Inner \varnothing mm	Outer \varnothing mm	Height mm	Inner \varnothing mm	Outer \varnothing mm	Height mm			
1	5 \pm 0,3	9 - 0,05	14,5 \pm 0,2	13 \pm 0,05	19 $^{+0,021}_{+0,008}$	14,5 \pm 0,2	2	> 2	106 131
5	8 \pm 0,3	17 - 0,05	15 \pm 0,2	21 \pm 0,05	35 $^{+0,025}_{+0,009}$	15 \pm 0,2	2	> 3	106 133
13	14 \pm 0,4	28,1 - 0,1	18 \pm 0,2	32,9 \pm 0,1	46 $^{+0,025}_{+0,009}$	18 \pm 0,2	2,4	> 3	106 134
25	14 \pm 0,4	34,5 - 0,1	18 \pm 0,2	38,7 \pm 0,1	54 $^{+0,030}_{+0,011}$	18 \pm 0,2	2,1	> 3	106 136
55	31 \pm 0,6	44,5 - 0,1	30 \pm 0,2	49,5 \pm 0,1	71 $^{+0,030}_{+0,011}$	30 \pm 0,2	2,5	> 4	106 138
100	22 \pm 0,6	55 - 0,2	30 \pm 0,2	60 \pm 0,1	85 $^{+0,035}_{+0,013}$	30 \pm 0,2	2,5	> 4	106 139
150	25 \pm 1,0	80 - 0,2	30 \pm 0,2	86 \pm 0,1	105 $^{+0,035}_{+0,013}$	30 \pm 0,2	3	> 5	106 140

Concentric ring couplings in HF 8/22 with air gap ≥ 3 mm

Table 2b

Torque Ncm*)	Inner magnet			Outer magnet			Air gap LL	Wall thickness of iron mounting mm	Type
	Inner \varnothing mm	Outer \varnothing mm	Height mm	Inner \varnothing mm	Outer \varnothing mm	Height mm			
10	14 \pm 0,4	28,1 - 0,1	18 \pm 0,2	38,7 \pm 0,1	54 $^{+0,030}_{+0,011}$	18 \pm 0,2	5,3	> 3	106 265
12	14 \pm 0,4	29,4 - 0,1	18 \pm 0,2	38,7 \pm 0,1	54 $^{+0,030}_{+0,011}$	18 \pm 0,2	4,65	> 3	106 266
13	14 \pm 0,4	29,4 - 0,1	30 \pm 0,2	49,5 \pm 0,1	71 $^{+0,030}_{+0,011}$	30 \pm 0,2	10,05	> 4	106 261
25	14 \pm 0,4	34,5 - 0,1	30 \pm 0,2	49,5 \pm 0,1	71 $^{+0,030}_{+0,011}$	30 \pm 0,2	7,5	> 4	106 264
26	31 \pm 0,6	44,5 - 0,1	30 \pm 0,2	60 \pm 0,1	85 $^{+0,035}_{+0,013}$	30 \pm 0,2	7,75	> 4	106 262
28	22 \pm 0,6	55 - 0,2	30 \pm 0,2	86 \pm 0,1	105 $^{+0,035}_{+0,013}$	30 \pm 0,2	15,5	> 5	106 260
105	49,5 \pm 0,1	71,0 $^{+0,035}_{+0,011}$	30 \pm 0,2	86 \pm 0,1	105 $^{+0,035}_{+0,013}$	30 \pm 0,2	7,5	> 5	106 263

*) Ncm \cong 100 cmp \cong 0,00738 ft lbs

Concentric ring coupling in SmCo

Concentric ring couplings in SmCo are advantageous to use, if rotational energy is to be transmitted through partitions. The utilisation of an electrically conductive partition walls induces eddy currents in the wall. This leads to eddy-current losses which, depending on the rpm., diminish the maximum torque. Furthermore, the eddy currents cause heat losses in the cylindrical partition wall in the air gap, so that cooling has possibly to be provided. The drive system must compensate for the additional eddy-current losses, meaning that the motor must be made larger by this dissipative component.

In order to ascertain the required torque, it is necessary to have precise knowledge of the drive system and of the load characteristic. Here, the user mostly has to rely on trials.

If the magnetic couplings are used for the pumping of aggressive media, then one part of the magnetic coupling must be given a metal or plastic (PTFE) protection. For practical reasons this will be the inner part, which should be protected with either speciality steel or plastic.

Heating of the magnetic material leads to a decrease in the magnetic flux density due to the temperature coefficient of the permanent-magnet material in use. This consequently means a reduction of the torque ($M \sim B^2$).

To make the most of the permanent-magnet material, the magnetic couplings must be optimised by means of calculation. A few couplings have been calculated with the aid of numerical-field programmes with finite elements, and the results are shown in Fig 9. This is intended to give the user the possibility of marking a rough estimate of the space requirements of a coupling. The axial length of concentric ring couplings should, where possible, be at least four times the air gap length. As magnetic stray fluxes occur increasingly in the front faces, these faces do not make a full contribution to the torque.

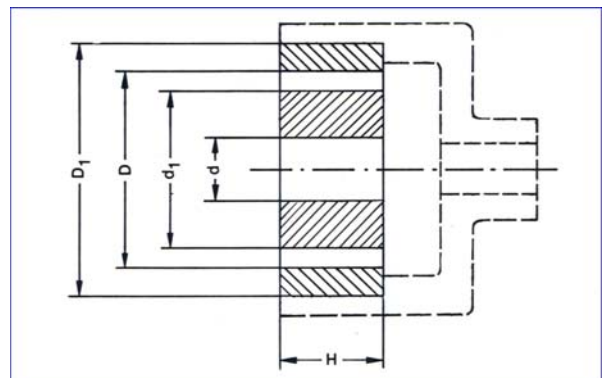

Figure 8
Concentric ring coupling in SmCo

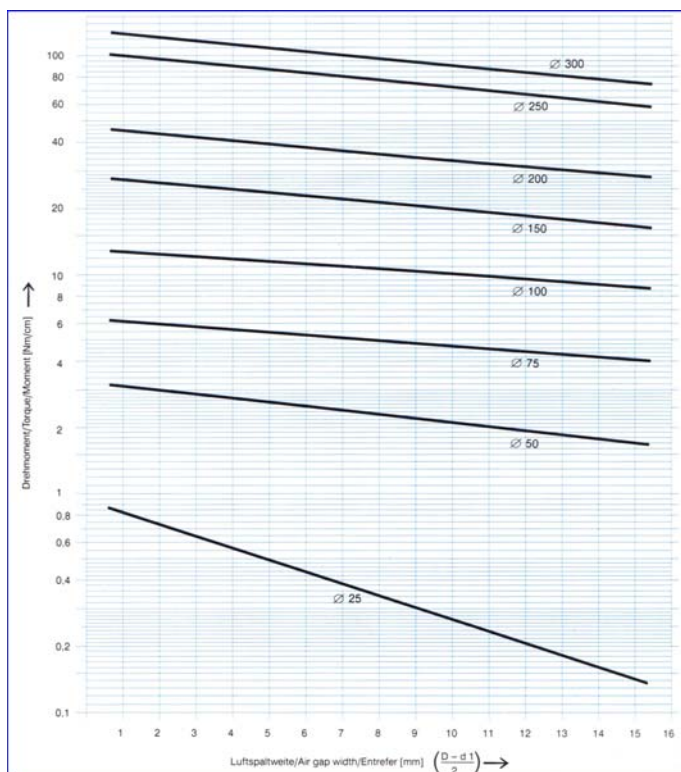

Figure 9
Torque per cm of axial coupling length as a function of the working air gap.

Parameter: outer diameter of the inner coupling part d_1 .

Intermediate dimensions for diameter d_1 and larger air gaps are possible, including protection of the inner part.

Hysteresis clutches and brakes

Among the hysteresis clutches and brakes produced by us, each non-magnetised hysteresis material e.g. AlNiCo 8/4 has, as an opposite, a magnetised permanent magnet material e.g. HF 24/20. The material combinations are varied according to application and required moment.

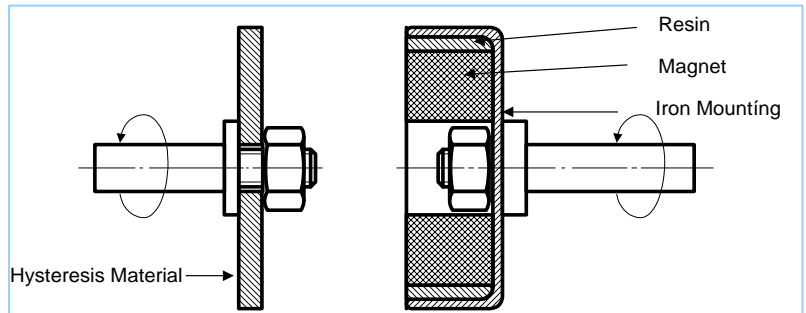

The torque or brake moment of the hysteresis combination is largely independent of the relative speed

(rpm) and is present even on very small rpm. Fig.10 shows a plan of this dependence for 2 different air gaps between drive and driven side. In practice, however, it is shown that at high relative speeds there is a slight increase in the moment because of a superimposed eddy current moment. Maximum temperature of the AlNiCo 8/4 disc may not exceed 400°C, as otherwise irreversible losses occur due to structural changes. Hysteresis clutches or brakes are generally useful where a constant moment is to be transferred over a large rpm. range.

If necessary, slight control of the torque is possible through axial displacement, that is by altering the air gap and thus the effective flux. It must be ensured, that there is no iron placed behind the AlNiCo 8/4 hysteresis disc, otherwise the transferable torque is considerably reduced. The distance between hysteresis disc and iron parts must be at least 15 mm.

Please find below an extract of our product range. Any other types are available on demand.

Hysteresis clutches and brakes HF 24/20, SmCo and AlNiCo

Torque in Ncm*) with air gap LL in mm			Magnet sizes			Sizes magnet with iron mounting		Bore in the iron mounting	Sizes of the hysteric disc			Type
1,0	1,5	2,0	Outer Ø mm	Inner Ø mm	Height mm	Outer Ø mm	Height mm	Ø mm	Outer Ø mm	Inner Ø mm	Height mm	
1,2	0,7	0,4	41 ± 0,6	24 ± 0,6	8	50 ± 0,2	9,5 ± 0,15	-	42 ± 0,2	6,4 ± 0,2	4 - 0,2	175 066
2,3	1,9	1,5	53 ± 0,7	23 ± 0,5	8	63 ± 0,2	10 ± 0,15	-	55 ± 0,2	8,4 ± 0,2	4 - 0,2	175 067
9,5	8	6	68 ± 1,5	32 ± 0,7	10	80 ± 0,25	13 ± 0,2	-	70 ± 0,2	8,4 ± 0,2	4 - 0,2	175 068
20	15	12	84 ± 4,0	32 ± 1,0	12	100 ± 0,25	16 ± 0,2	-	85 ± 0,2	10,5 ± 0,2	4 - 0,2	175 069
35	31	27	100 ± 2,0	50 ± 1,0	15	125 ± 0,25	20 ± 0,2	-	105 ± 0,2	10,5 ± 0,2	4 - 0,2	175 070
70	55	42	124 ± 3,0	56 ± 3,0	18	150 ± 0,3	24 ± 0,2	-	130 ± 0,2	13,0 ± 0,2	4 - 0,2	175 071
115	103	90	140 ± 2,0	70 ± 1,0	21	165 ± 0,3	27 ± 0,2	-	145 ± 0,2	13,0 ± 0,2	4 - 0,2	175 072
172	130	100	117	42,2	10	117	12,5	40	114	45,0	3,5	175 073 ¹⁾
200	190	177	180	80	20	195	28 ± 0,2	32 ± 0,05	185 ± 0,3	45,0 ± 0,1	4 - 0,2	175 074 ¹⁾
270	240	220	212 ± 2,0	68 ± 1,0	20,5	235	27 ± 0,3	6	215 ± 0,2	6,0 ± 0,2	4	175 075 ¹⁾
63	53	44	85 ± 1,0	32	10	100 ± 0,25	13 ± 0,2	32	114	45,0	3,5 ± 0,15	175 076 ²⁾
400	270	110	140	60	10	150 ± 0,3	16 ± 0,2	25 ± 0,05	143 ± 0,1	25,0	14,5	175 077 ²⁾
650	625	600	140	60	9	165 ± 0,3	14,5 ± 0,3	-	150	-	23,5	175 078 ²⁾
9,5	8	6	68 ± 1,5	32 ± 0,7	10	80 ± 0,25	13 ± 0,2	30 ± 0,1	70 ± 0,2	16,0 ± 0,1	4 - 0,2	175 110

Table 3

*) 1 Ncm=100cmp=0.00738 ft lbs

¹⁾ Special type in Hartferrit

²⁾ Special type in SmCo

Special types cannot be delivered from stock.

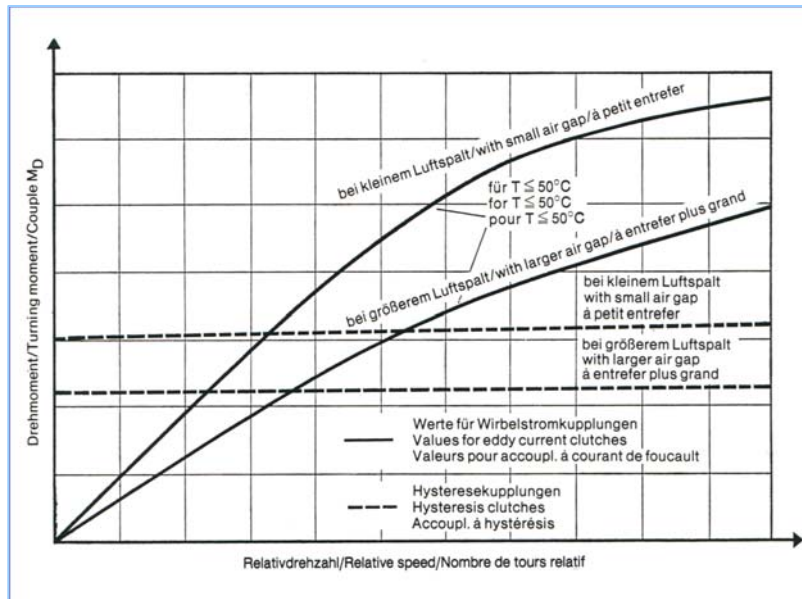

Figure 10

Diagrammatic representation of torque of hysteresis and eddy current clutches dependent on relative speed

Eddy current clutches and brakes

In contrast to the drive and brake elements described previously, the torque in eddy current clutches and brakes (fig.4) is only produced by a relative speed between drive and driven sides.

Thus the transferable moment increases with the relative rpm. Fig. 10 shows the torque gradient for two different air gaps. In practice rings or segments in permanent magnet material e.g. HF 24/20 are magnetised on one side with several poles and on the other hand we find a copper disc 2-5 mm thick, which for magnetic reasons has a soft iron backing of 2-6 mm thickness. Table 4 compares the torques, which can be achieved by eddy current clutches and brakes for 3 different relative rpm. and various air gaps.

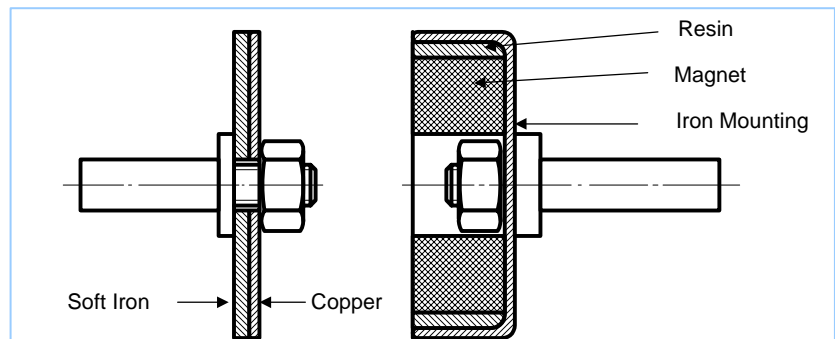

The given values relate to room temperature which was set by measurements of corresponding cooling of the copper discs. In eddy current clutches and brakes the temperature coefficient of the copper is considered along with the temperature coefficient of the magnet. Eddy current clutches and brakes heat up considerably due to the development of eddy currents with increasing rpm.; with temperature increase the value of the torque attainable decreases considerably. If cooling is not provided, temperatures up to 200°C at relative rpm of 1000/min can occur on the copper disc whereby the torque decreases by 50%. The losses thereby incurred are partly irreversible. They can only be recovered by remagnetisation. If the temperature is kept below 50°C, the decrease in torque is only about 10%.

In certain rpm ranges eddy current clutches show a roughly proportional or constant torque – rpm. – characteristic. This means, eddy current clutches are suitable for use in coil machines where constant band tension and constant band speed are required. For details please refer to special literature ²⁾.

²⁾ e.g. Brinkmann, K.: „Aufpulvorrichtung mit permanentmagnetischer Wirbelstromkupplung“, „Draht“, specialist magazine for wire manufacture, wire processing, wire treatment 13 (1962) pages 53-59.

Please find below an extract of our product range.
Any other types are available on demand.

Eddy current clutches and brakes in HF 24/20, SmCo and Cu/Fe

Torque in Ncm*) with air gap LL in mm			With relative speed n 1/min	Magnet sizes			Sizes magnet with iron mounting		Bore in the iron mounting Ø mm	Eddy current unit				Type
0,5	1,0	2,0		Outer Ø mm	Inner Ø mm	Height mm	Outer Ø mm	Height mm		Outer Ø mm	Inner Ø mm	Cu-thickn. mm	Fe-thickn. mm	
1,0	0,8	0,6	500											
2,0	1,6	1,1	1000	41 ± 0,6	24 ± 0,6	8	50 ± 0,2	9,5 ± 0,15	-	50	6,4	2	2	175 019
2,8	2,2	1,5	1500											
4,9	3,8	2,5	500											
9,3	7,5	5	1000	53 ± 0,7	23 ± 0,5	8	63 ± 0,2	10 ± 0,15	-	63	8,4	2	2	175 020
13	10,5	7	1500											
26	19	14	500											
47	35	25	1000	68 ± 1,5	32 ± 0,7	10	80 ± 0,25	13 ± 0,2	-	80	8,4	2	3	175 021
59	47	35	1500											
75	56	42	500											
130	100	75	1000	84 ± 4,0	32 ± 1,0	12	100 ± 0,25	16 ± 0,2	-	100	10,5	2	3	175 022
160	120	93	1500											
135	110	75	500											
180	150	105	750	85 ± 1,0	32	10	100 ± 0,25	13 ± 0,2	32	100	10,5	3	4	175 023^{*)}
200	175	125	1000											
140	120	90	500											
190	170	130	750	100 ± 2,0	50 ± 1,0	15	125 ± 0,25	20 ± 0,2	-	125	10,5	3	4	175 024
230	210	155	1000											
450	380	300	500											
580	500	400	750	124 ± 3,0	56 ± 3,0	18	150 ± 0,3	24 ± 0,2	-	150	13,0	3	4	175 025
650	580	470	1000											
600	520	400	500											
760	670	510	750	140 ± 2,0	70 ± 1,0	21	165 ± 0,3	27 ± 0,2	-	165	13,0	3	4	175 026
800	700	530	1000											
1300	1100	650	500											
1500	1300	850	750	140	60	10	150 ± 0,3	16 ± 0,2	25 + 0,05	150	25,0	4	6	175 027^{*)}
1600	1400	950	1000											
1030	870	670	500											
1300	1150	870	750	180	80	20	195	28 ± 0,2	32 + 0,05	195	45,0	3	4	175 028^{*)}
1400	1200	900	1000											
2300	2220	1800	500											
2500	2300	1900	750	214 ± 2,0	68 ± 1,0	21	235	27 ± 0,3	-	230	55,0	4	5	175 029^{*)}
2600	2400	2000	1000											

Table 4

*) 1 Ncm = 100 cmp = 0.00738 ft lbs

1) Special type in Hartferrit

2) Special type in SmCo

Special type cannot be delivered from stock.

Technical advice and supply of samples

Normally every mass production of permanent magnetic clutches is preceded by the testing of a trial model. For eddy current and hysteresis clutches and brakes this is advisable in every case as the moment curves can alter according to application e.g. through heating. Magnet rings and segments of disc couplings, eddy current and hysteresis clutches and brakes are stuck with special adhesive to the iron parts or to the cup filled with special resin. If high chemical and thermal resistance is necessary, we would like to obtain details accordingly. For mounting clutches and brakes, holes can be made in the iron cups up to the maximum ID of the magnets. Furthermore, counter-balancing is possible through making holes on the outer perimeter. If care is taken during this work to ensure that the clutches and brakes do not heat above 150°C, no irreversible weakening of the transferable torque will occur.

Complete clutches and brakes ready for installation can be supplied. However, it is also possible to send to us for installation and magnetisation the bells and receptacles into which the magnets are to be mounted. The outer rings of the concentric ring couplings can be put into the bells in various ways independent of form, size and no. of the rings lying one behind the other. For this reason it is necessary to send a drawing with any enquiry showing the planned receptacle for the magnet rings, so that we can establish the most favourable mounting method. The OD of the magnet rings is ground to ISA m6 fitting so that we also have the possibility of using a press fit. The details for wall thickness of the iron mountings are for low carbon steel e.g. St 37. In the inner parts of concentric ring couplings the shafts are usually integrally cast.

As far as possible every construction should be discussed with us in order to avoid failure. We are always ready to give advice. Data-programmes are available.

Mass Production

For constructional reasons, designs are often required for mass production of couplings and brakes which do not correspond to the normal designs given in this brochure. In such cases, the following alternative steps can be taken:

- The customer takes magnetised rings or unmagnetised rings which he magnetises himself and fits to a drive assembly
- The customer gives us the mountings for the couplings and brakes, and we complete everything
- We produce the complete coupling in accordance with customer's drawing.

Otherwise for mass production we recommend the agreement of technical delivery instructions in which all requirements as regards magnetic, physical, mechanical and chemical properties appertaining to our products are stipulated. We can give no guarantee against faults resulting from factors outside those agreed in the technical instructions.

General Note (liability)

All statements as to the properties or utilisation of the materials and products mentioned in this brochure are only for the purpose of description. Guarantees in respect of the existence of certain properties or utilisation of the material mentioned are only valid if agreed upon in writing.