

Electromagnetic spreading magnets

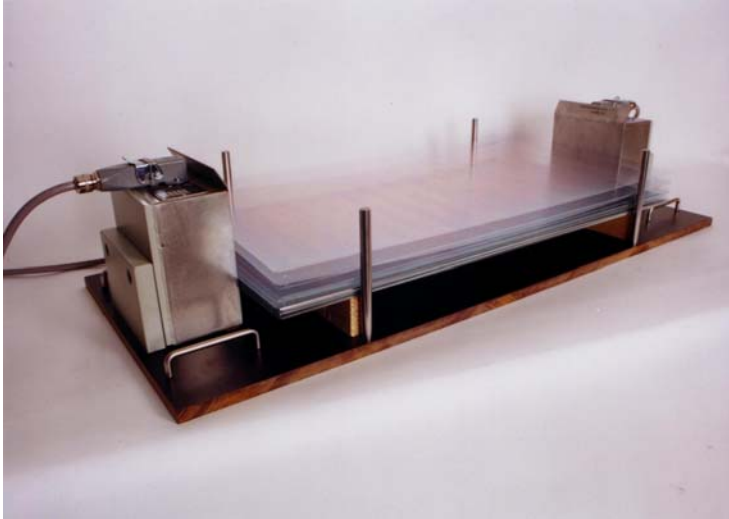

In case of electromagnetic spreaders the magnetic flux is not generated by permanent magnets, but by coils (solenoids). Depending on the arrangement (two- pole or three- pole) two or three coils are applied. The kind of operation is the same as with permanent magnetic spreaders, however with some restrictions to be explained below.

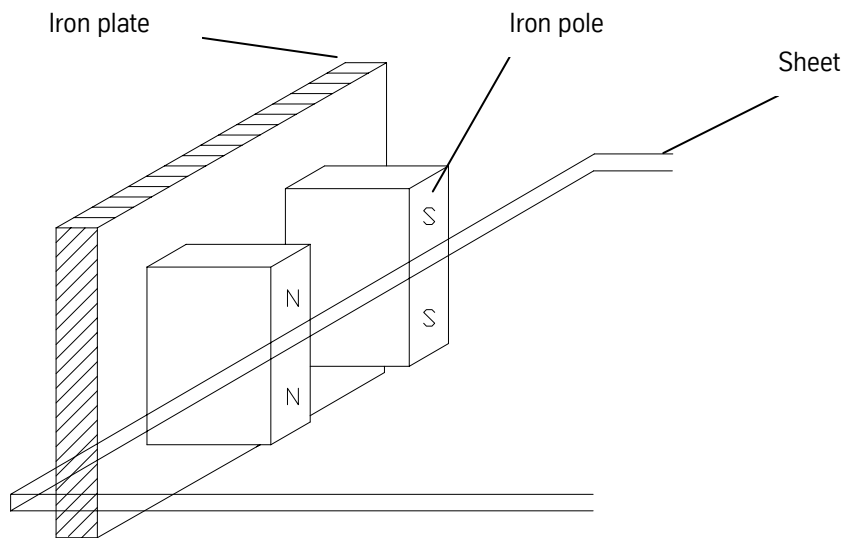

Typical arrangement of a conventional, electromagnetic spreader

It has to be stated first that the spreading effect is not the same from the lower edge to the upper edge of the spreading magnet, because the end windings of the coils cause a thinning of the lines of electric field strength and thus a reduced magnetic flux. This becomes noticeable by a reduced spreading performance at the lower and upper ends of the system. In order to compensate this effect as far as possible, a iron strip is attached to the magnetic pole surrounded by the coil; this strip exceeds the end windings and extends the lines of magnetic flux to the lower edge of the system.

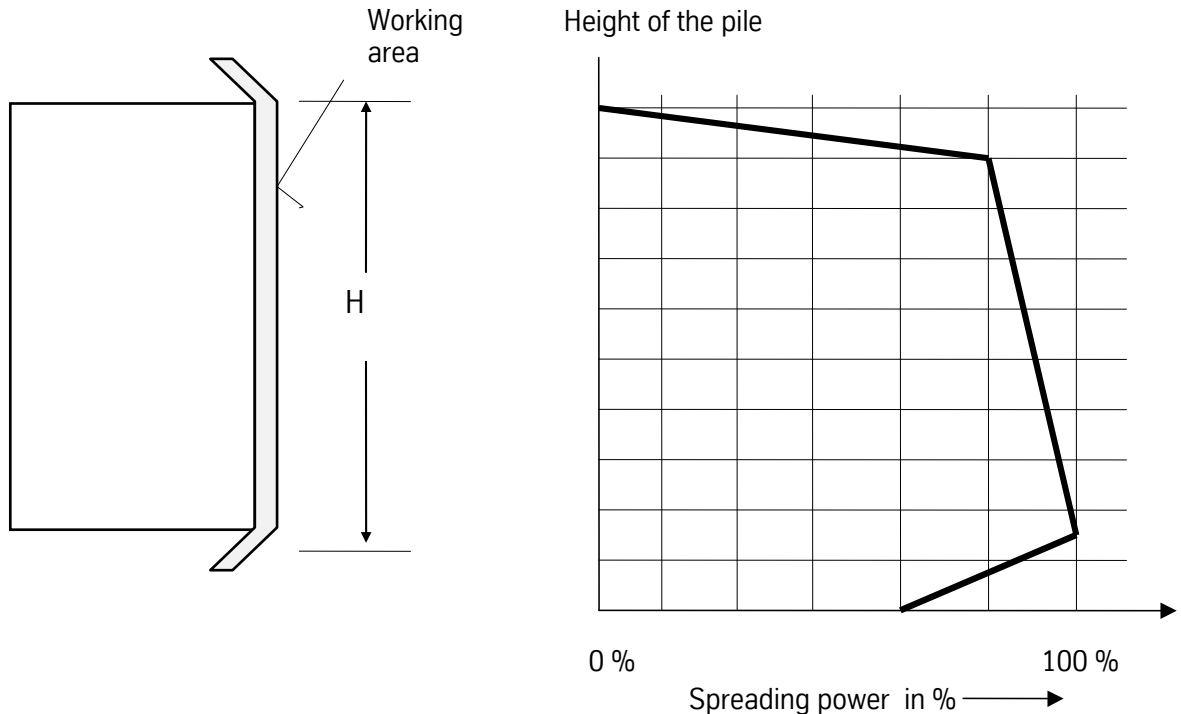

Spreading power in dependence of the covered piling height

A further effect of the reduced spreading performance is to be seen in the fact that the sheets already lying on the pile have the same effect as a magnetic short-circuit and reduce the spreading performance in the upper part of the system. This phenomenon can be reduced by grooving the centre pole; thus the effect of the magnetic short-circuit is nearly eliminated. In case of permanent magnetic spreaders the short circuit is of minor importance, because the relative permeability μ_r is near 1 and thus the magnet is stable even in the upper part. The relative permeability at the iron poles is near 200 which makes the guidance of the lines of magnetic flux 'softer'.

Electromagnetic spreaders are in principle electromagnets with special designed poles. Their dimensions start with a width of 100mm, whereas the system height, due to the special purpose, reaches from 130mm up to 600mm. The depth of the system or the thickness is restricted in normal case to less than 100mm. The max. system width referring to a system with four poles can reach up to about 400mm. In this case, the spreaders are able to fan sheet up to a thickness of 8mm.

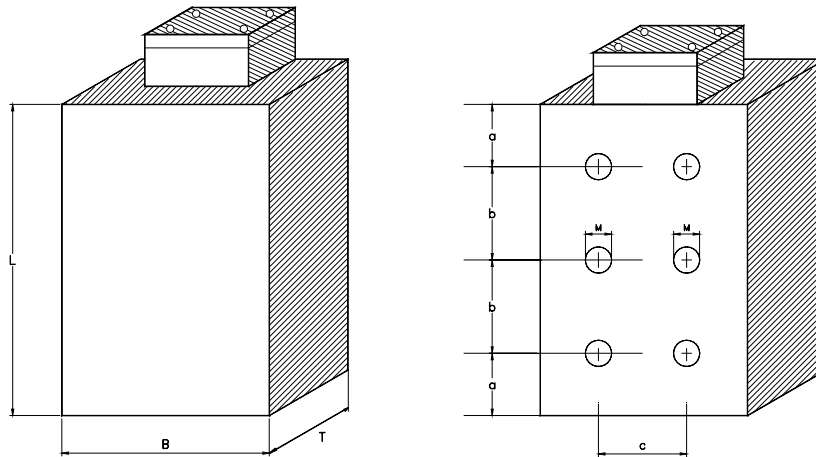

Type	B[mm]	L[mm]	T[mm]	U[V]	I[A]	ED [%]	Thickness of the sheet up to
ESP 105/420	105	420	90	200	2,0	30	2 mm
ESP 105/420	105	420	90	510	1,15	30	2 mm
ESP 105/420	105	420	90	300	1,5	30	2 mm
ESP 105/600	105	600	90	510	1,3	30	2 mm
ESP 110/90	110	90	75	190	0,45	50	2 mm
ESP 144/190	144	180	190	200	1,3	60	5 mm
ESP 144/130	144	130	87	200	0,6	50	2 mm
ESP 150/160	150	160	90	200	0,9	50	3 mm
ESP 150/200	150	200	90	200	1,35	50	3 mm
ESP 215/130	215	130	90	200	1,12	50	4 mm
ESP 215/130	215	130	90	100	1,3	50	4 mm
ESP 215/200	215	200	90	200	1,5	50	4 mm
ESP 320/332	320	330	95	200	5,1	30	8 mm
ESP 320/632	320	630	95	200	9,8	30	8 mm

Further dimensions on request!

Prices and delivery time depend on the desired quantity.

Appropriate electronic devices for the power control can be supplied on request as:

- control system realized by a power transformer with 4 outputs and B4 rectifier
- control system with thyristor steering and analogue input 0 to 10V acc. 0 to 100%
- control system with current regulation due to puls width modulation